

REV	DATE	DESCRIPTION	BY

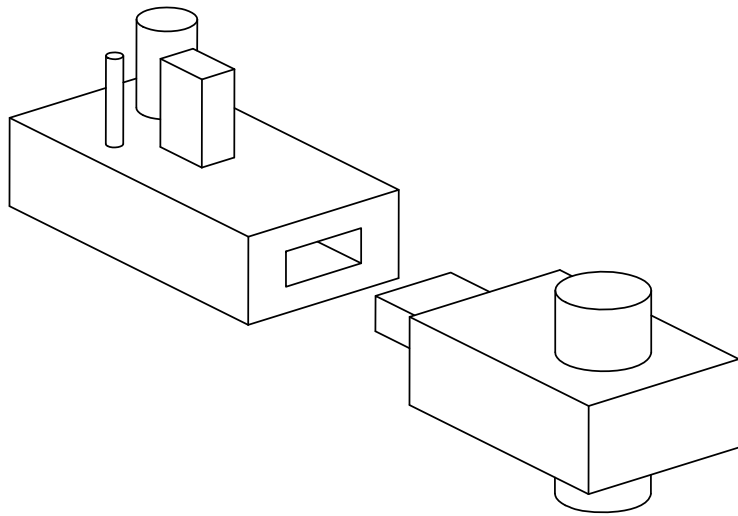

EXAMPLE 1

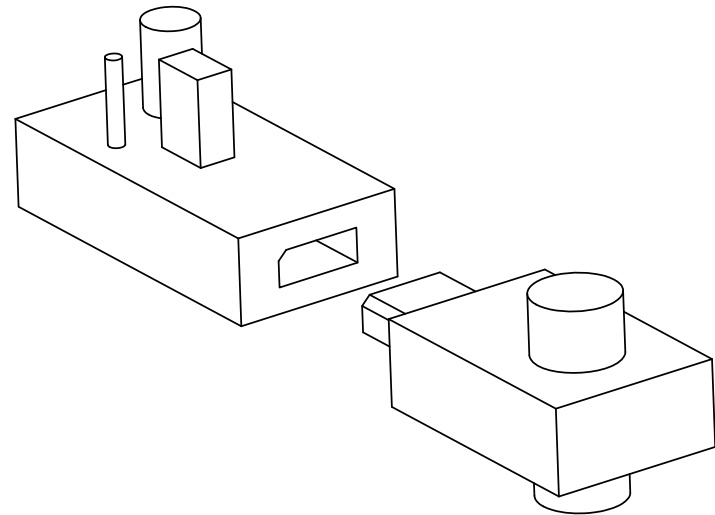

EXAMPLE 2

UNLESS OTHERWISE SPECIFIED:  DIMENSIONS ARE IN INCHES TOLERANCES: ±.005 FRACTIONAL: ±.010 ANGULAR: ±0.5° TWO PLACE DECIMAL: ±.010 THREE PLACE DECIMAL: ±.005		NAME	DATE	<b>ENGINEERING DESIGN SOLUTIONS</b> PO Box 5756 - Clearwater, FL 33758
	DRAWN	G. M.	9-6-10	
	CHECKED			
	ENG APPR.			
	MFG APPR.			
INTERPRET GEOMETRIC TOLERANCING PER:				TITLE:  <b>DFA EXAMPLES</b>
MATERIAL	COMMENTS:			SIZE <b>A</b>
FINISH				DWG. NO.
				REV
				SCALE: 1:2
				SHEET 1 OF 1

**PROPRIETARY AND CONFIDENTIAL**  
THE INFORMATION CONTAINED IN THIS DRAWING IS THE SOLE PROPERTY OF ENGINEERING DESIGN SOLUTIONS. ANY REPRODUCTION IN PART OR AS A WHOLE WITHOUT THE WRITTEN PERMISSION OF ENGINEERING DESIGN SOLUTIONS IS PROHIBITED.

NEXT ASSY	USED ON
APPLICATION	

DO NOT SCALE DRAWING